

SMARTBAFFLE

BY DCI



The Bigger Better Insulation Baffle



- Strongest & Smartest Insulation Baffle
- Perfect with Spray Foam or Fiberglass
 - Ventilates Entire Rafter Bay Width
 - Installs From Rooftop or Attic Area
 - Will Not Crush, Tear or Break

1-800-622-4455
WWW.DCIPRODUCTS.COM



SmartBaffle by DCI

(Rugged Insulation Baffle)

Description: The **SmartBaffle** is designed to fit 16" & 24" on center rafters and can be customized for different rafter widths. **SmartBaffle** will support spray foam, loose fill, fiberglass or any other insulation materials.

SmartBaffle is designed for rugged, unbreakable use and handling. **SmartBaffle** is constructed of non-collapsing material with lifetime durability. Insulation should fit loosely in the remaining rafter space to gain the maximum 'R' value (winter) and 'U' value (summer).

SmartBaffle allows 2" of air flow between rafters, which is more than double any competitor product. To create a wider or more narrow **SmartBaffle** for uneven rafter spaces, and to see the different attachment methods, please reference the installation instructions enclosed within the box or visit www.dciproducts.com

SmartBaffle 16 & 24 Specifications:

MODEL NUMBER:	(SB16) SmartBaffle 16 used for 16" rafter spacing (SB24) SmartBaffle 24 used for 24" rafter spacing
PRODUCT DIMENSIONS:	(SB16) 18.5"W X 37.5"L X 1/8" Thick (SB24) 26.5"W X 37.5"L X 1/8" Thick
MINIMUM ORDER:	1 Box (36 Pieces)
TERMS:	Net 30
TOTAL BOX QUANTITY:	36 Pieces Per Box
TOTAL SKID QUANTITY:	16 Boxes or 576 Pieces
TOTAL BOX WEIGHT:	(SB16) 34 lbs per box • (SB24) 47 lbs per box
INDIVIDUAL BOX DIMENSIONS:	(SB16) 7.5" High x 19.5" Wide x 39" Long (SB24) 7.5" High x 27.5" Wide x 39" Long
PALLET WEIGHTS & SIZES:	SB16 - 580 lbs 39" Long x 39" Wide x 66" High SB24 - 795 lbs 48" Long x 40" Wide x 66" High
INCLUDED ITEMS:	Installation Instructions
RETURN POLICY:	30 DAYS UNCONDITIONAL MONEY BACK GUARANTEE. Unopened boxed products can be returned to stock within 30 days of purchase. Call first for approval. That which cannot be restocked is to be returned to DCI Products with invoice and reason for return. Upon receipt of those items DCI may replace or refund the amount of the returned merchandise after DCI approval. Only full cartons of each product may be returned in the original box tightly sealed to our location at customers expense.

DCI Products Inc.
415 S. Penn Street
Clifton Heights, PA 19018
Phone: 1-800-622-4455
Fax: 1-888-356-3291
www.dciproducts.com

Installation of SmartBaffle 16 & SmartBaffle 24

(SmartBaffle is available for 16" or 24" rafter spaces, respectively)

- 1- To install the SmartBaffle simply bend up the 2" side flanges with the routed flange grooves facing the insulation. Insert the flanges into the rafter space ensuring that they rest against or near the underside of the roof decking. The flanges will automatically leave a 2" air space between the roof deck and the lower panel of the SmartBaffle. Slide the SmartBaffle down towards the fascia board to about 3" short of the inner side of the fascia board. This allows room for air flow from under the soffit. SmartBaffle is also designed to be used with SmartVent intake ventilation (www.dciproducts.com) to ensure insulation is not blocking the proper airflow through the SmartVent opening.
- 2- The SmartBaffle (Fig. 1) can simply rest in place, or a small nail can be placed proximate the middle on each side below the baffle, ensuring the flanges are pressure tight to the roof deck. Install as many SmartBaffles as needed to create the rafter air chute *ensuring* that a clear, continuous air channel is present between the soffit intake air and the roof's exhaust air or ridge vent and the underside of the roof deck. For multiple chute installations in one rafter bay simply allow 1/4" space between two adjoining baffles. This allows the fiberglass insulated rafter space below the baffle to breathe into the air chute created. When using spray foam insulation, SmartBaffles should simply butt each one tightly or overlap slightly to ensure the foam does not penetrate the air chute.
- 3- To create a smaller size SmartBaffle for narrow rafter spaces, simply cut the one long side, about four inches (4") wider than the width of the rafter space. Next, use a utility knife to cut "half way through" a mark made 2" in from the SmartBaffle cut off edge. This will create a flange that bends up towards the roof deck. You may practice this cut on a scrap piece of baffle material prior to working on the installed SmartBaffle to become familiar with the 1/2 cut. Another way is discussed in step #4.
- 4- **Things to remember:** ensure insulation is not inside the 2" air chute created between the roof deck and the SmartBaffle. Install SmartBaffle in all rafter spaces that have soffit intake air flow that may be blocked by insulation. Use a utility knife to make cuts. Larger size spaces can follow the next directions in step #5. **Tip:** To create a smaller baffle, cut the SmartBaffle long ways 1/2" less than the width of the rafter space (allowing for the flanges bending up). Once separated, overlap at the cut edges creating the size required including the flange allowances (Flange allowance is 4"). Screw the overlapped long edges together using eight 1" long screws (max.) pointed towards the roof deck for safety purposes. Using this method the space between the routes in the SmartBaffle would be the space between the narrow rafter space.
- 5- To create a larger SmartBaffle (Fig. 2) simply screw two flat SmartBaffles together with maximum length 1" screws (eight screws with screw points toward the roof deck when installed) ensuring the width is 4" wider than the rafter space (this allows for the 2" flanges). Then install per the above directions. Below is a sketch of the SmartBaffle installation inside a rafter space.

Any Questions Please Call 1-800-622-4455 (EST) or visit www.smartbaffle.com .

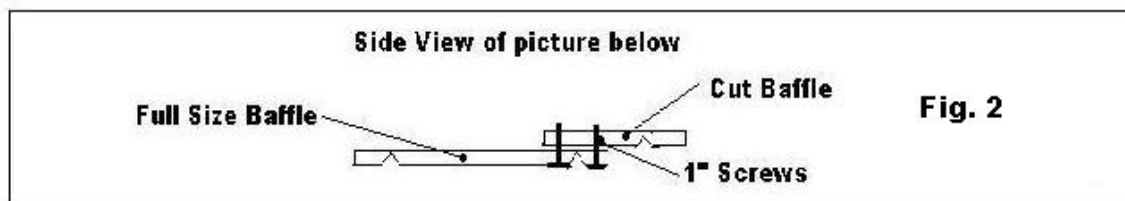
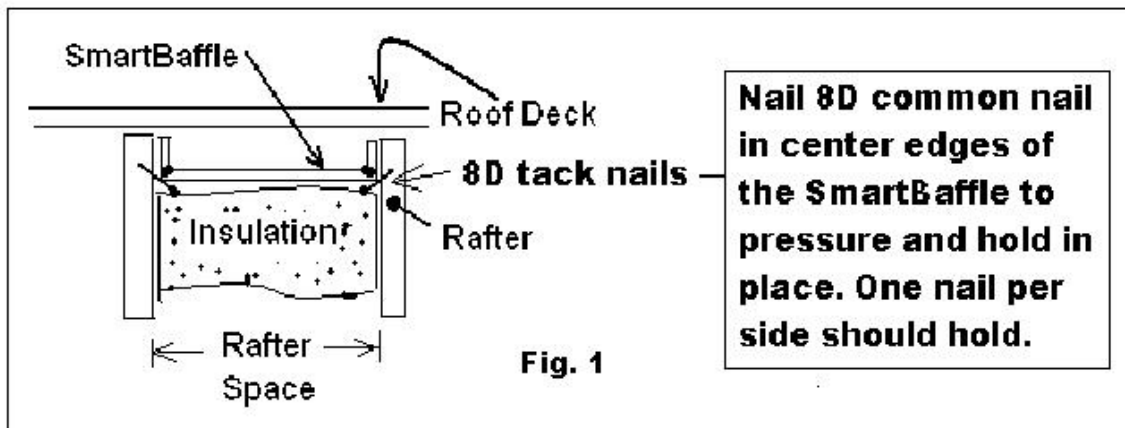

DIRECTIONS FOR CUTTING A SMALLER SMARTBAFFLE

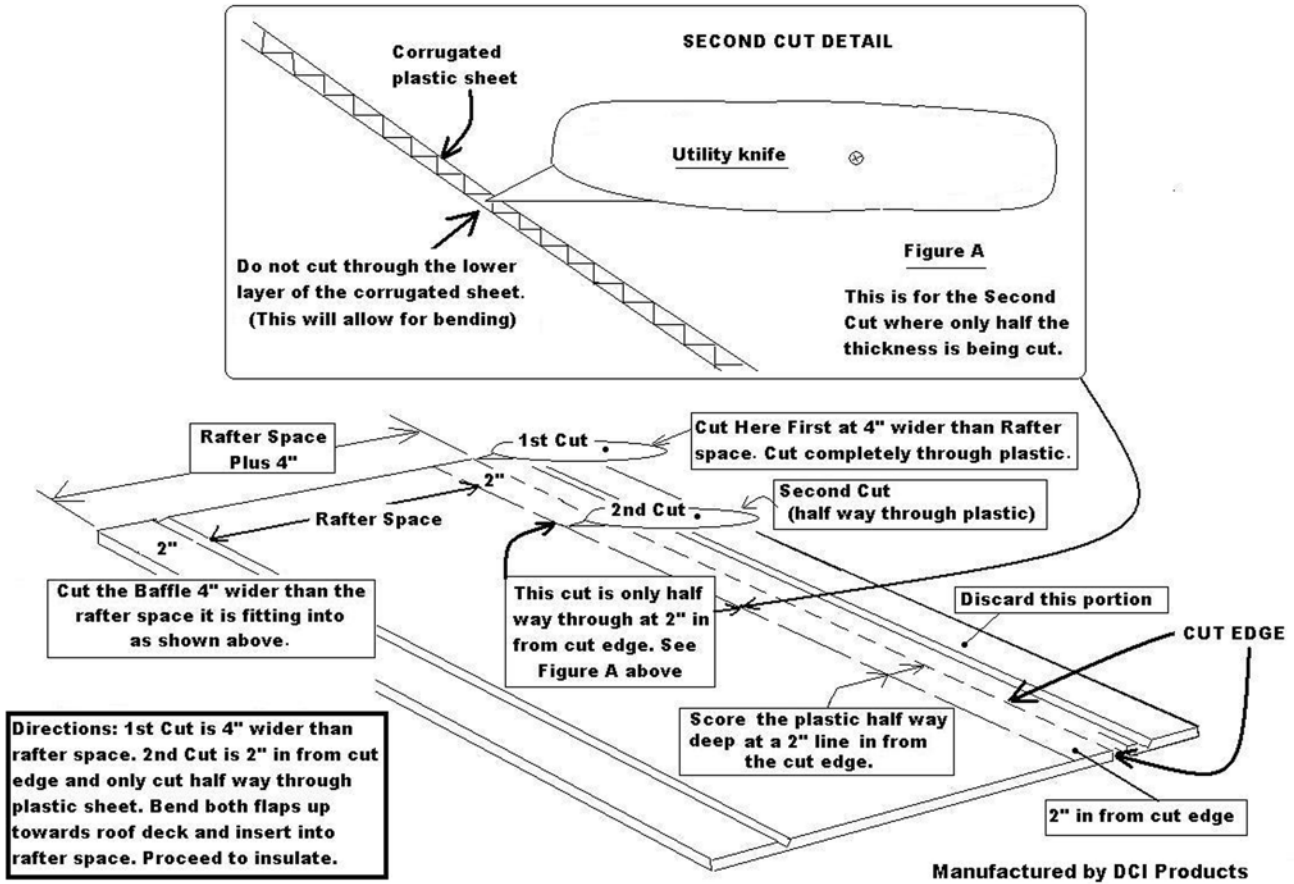

DIRECTIONS FOR MAKING A WIDER SMARTBAFFLE

Note: SmartBaffle is available for 16" rafters (SmartBaffle 16) and for 24" rafters (SmartBaffle 24)

Manufactured by DCI Products

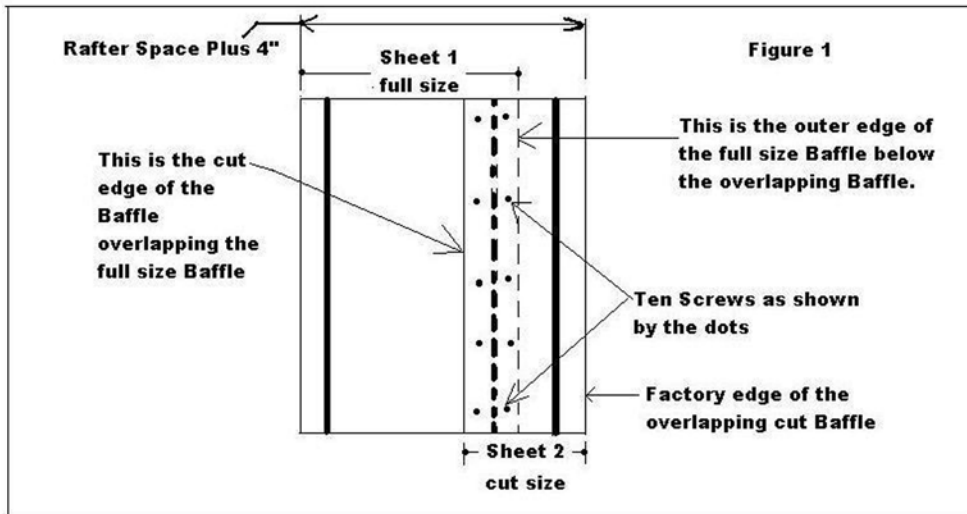

DIRECTIONS TO MAKE A WIDER BAFFLE:

Fig. 1- overlap a portion (half sheet length wise) on top of a full sheet of SmartBaffle. Attach 10 screws 1" long connecting the sheets together. The overall SmartBaffle width size should be 4" wider than the rafter space it will be used in. Once attached bend up the outer 2" flaps so they form a 90 degree bend. Insert into rafter space. Continue with as many as needed ensuring the space distance is the same.

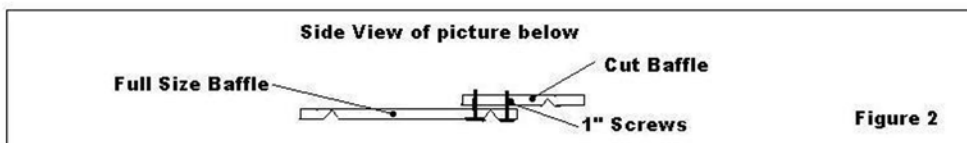

Fig. 2- a cross section of Fig. 1 showing the overlay of the cut piece above the full SmartBaffle and screws for attachment.